

EXO CLEAN

MOBILE FILTRATION STATION



- KEEPS FACTORY CLEAN
- PLUG AND PLAY AND QUIET (< 68 dB)
- REDUCED ELECTRICAL CONSUMPTION (0,14 kW)
- PREVENTS OPERATOR FROM BREATHING DANGEROUS POLLUTANTS

EXO CLEAN S | M



2024 EN | 01 | 01



EXOCLEAN WORKING PRINCIPLE

ExoClean is a compact mobile filtration station that ensure safe and clean process of blowing oily parts. ExoClean is equipped with a single phase electrical motor with extremely low consumption and noise level. Oilmist generated by the process of blowing parts is conveyed into the lower

section of the cabin where oil is recollected into a easily removable 5 litres drainage tank. The mist is filtered by an M5 fiberglass cell that allows cleaned air recirculation inside the shop.

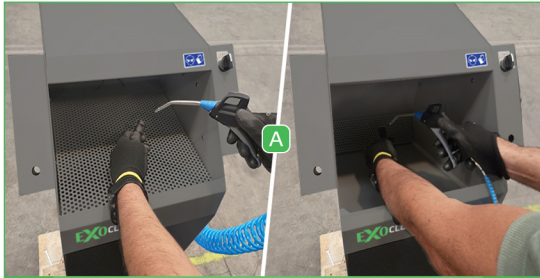

- A** TWO WORKING MODES: OPEN SPACE OR WITH SUPPORT GRILLE
- B** LED LIGHT FOR BETTER OPERATION ON WORKING AREA
- C** TWO AIR FLOW SWITCH FOR OPTIMAL USE
- D** INTEGRATED HIGH QUALITY AIR GUN
- E** M5 MICROFIBER FILTER CELL OF GLASS
- F** FIVE LITERS DRAINAGE TANK WITH INSPECTION WINDOW AND LED LIGHT

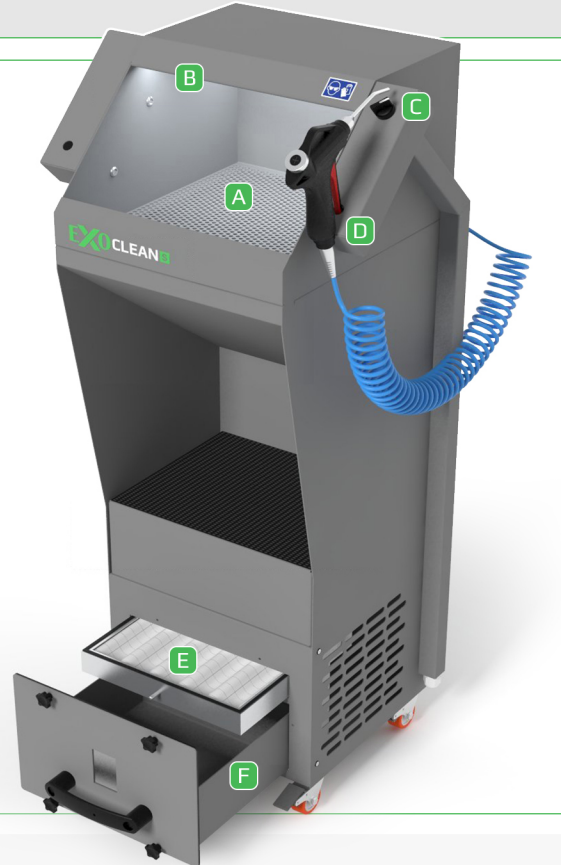

EXOCLEAN DIMENSIONS AND TECHNICAL DATA

ExoClean is available in two versions: **ExoClean S** is compact size ideal for parts up to 20 cm; **ExoClean M** is medium version ideal for parts up to 30 cm.

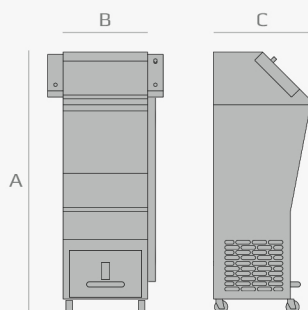

	S	M
DIMENSION A x B x C (mm)	1070x350x400	1070x500x400
MOTOR (kW)	0.14 220/1/50	0.14 220/1/50
SOUND LEVEL ELECTRICAL MOTOR (dB)	65	65
TANK CAPACITY (L)	5	5
WEIGHT (kg)	37	45
PRESSURE (Pa)	SPEED 1 = 586 SPEED 2 = 701	

INFORMATION IS SUBJECT TO CHANGE WITHOUT NOTICE

EXOTUT srl

SEDE 1: VIA ALCIDE DE GASPERI N.3
24069 | CENATE SOTTO - BG | ITALY

SEDE 2: VIA ZANICA N.26
24050 | GRASSOBBIO - BG | ITALY

+39 035 03 95 038
INFO@EXOTUT.COM
WWW.EXOMIST.COM

EXOMIST™
CLEANER PRODUCTIVITY

MADE IN ITALY

DISTRIBUTORS